

BETSO

TCX-2

Ultra compact highly accurate Time Code transceiver

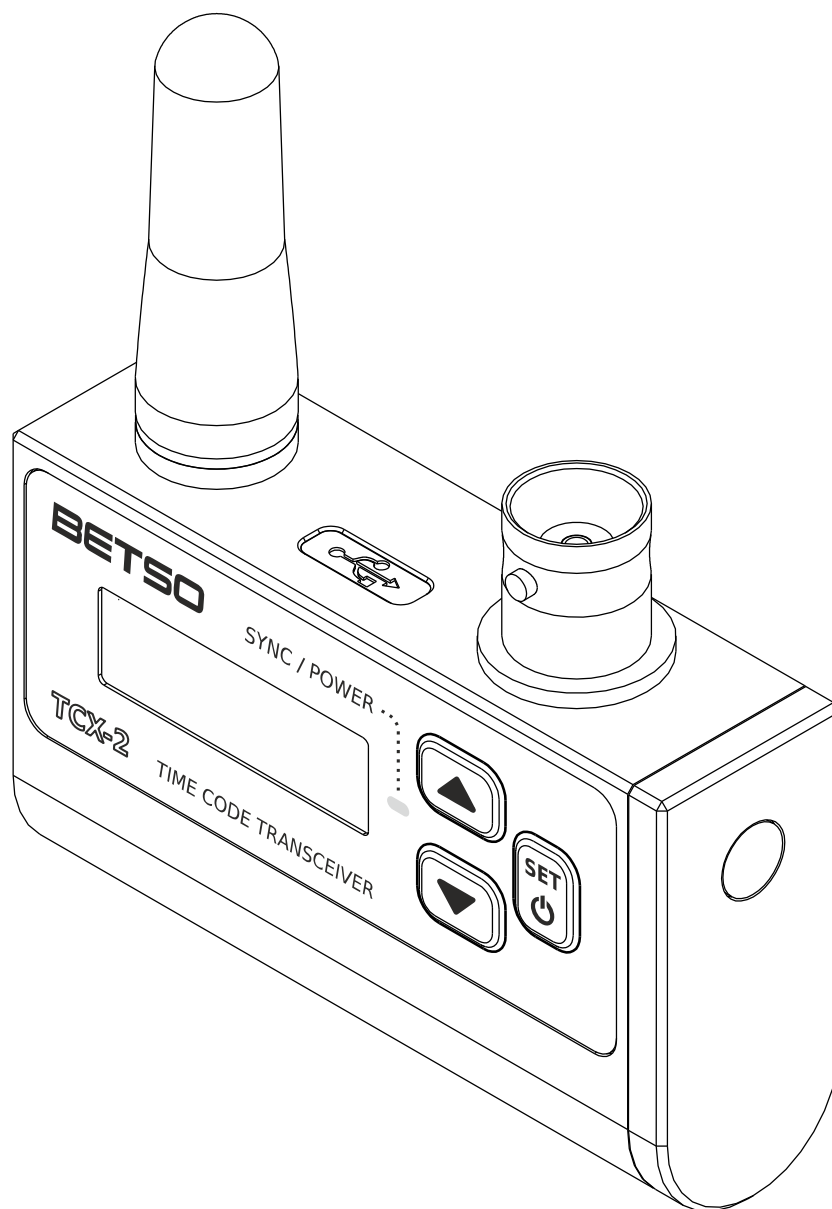

Contents

1. Product description.....	4
2. Top features.....	4
3. Control elements.....	5
4. Insertion of battery / accumulator.....	6
5. Turning ON/OFF.....	6
6. Menu control.....	6
7. Setting of TCX-2.....	7
7.1 Time code.....	7
7.1.1 Frame rate * - setting frame rate of generated Time Code.....	7
7.1.2 Amplitude - setting amplitude of generated Time Code.....	8
7.1.3 Default * - setting of default Time Code start time/frame.....	8
7.1.4 Offset - setting of Time Code offset for jamming or RF transmission.....	8
7.1.5 User bits - setting of User Bits of generated Time Code.....	9
7.1.6 Auto on - setting of automatic power on when TC source is connected.....	9
7.1.7 Jamming * - setting of jamming to external TC source.....	10
7.1.8 Cross jamming * - jamming TCX-2 with different TC frame rate.....	10
7.1.9 Jamming calibration - calibration to TC source during jamming.....	11
7.2 Wireless.....	11
7.2.1 Unit type - setting of wireless behaviour of TCX-2.....	11
7.2.2 Channel - setting of RF time code system channel.....	12
7.2.3 Location - setting of usage location for regulatory compliance.....	12
7.3 Special.....	13
7.3.1 Copy TX TC-IN to RX TC-OUT.....	13
7.3.2 Battery type – setting type of battery powering TCX-2.....	14
7.3.3 OLED brightness – setting of OLED display brightness.....	14
7.3.4 OLED power save mode – setting of OLED power save function.....	14
7.3.5 Display orientation – setting of OLED display orientation.....	15
7.4 System.....	15
7.4.1 Serial number - serial number of TCX-2.....	15
7.4.2 Upgrade to TCX-2+ - allows TCX-2 FW upgrade.....	15
7.4.3 HW version - version of hardware of TCX-2.....	16
7.4.4 SW version - version of software of TCX-2.....	16
7.4.5 GPS calibration – calibration of internal TCXO using GPS module.....	16
7.4.6 Contains FCC ID: 2AJWB-RFM1 - inbuilt transmitter module.....	16
7.4.7 Contains IC: 21968-RFM1 - inbuilt transmitter module.....	17
8. Control of TCX-2.....	17
8.1 Unit type of TCX-2 is set to RF OFF *.....	17
8.2 Unit type of TCX-2 is set to TX.....	18
8.3 Unit type of TCX-2 is set to RX.....	18
9. Informative LED function.....	18
10. Recommended accessories.....	20
11. Troubleshooting.....	20
12. Technical specification.....	21

13. BNC connector wiring.....	22
14. FCC regulatory information (USA) FCC Statements.....	22
15. Industry Canada (IC) regulatory information.....	23
16. Avis de conformité à la réglementation d'Industrie Canada.....	24
17. EC Declaration of conformity.....	25

Used symbols



Indicates text that has only informative character. If you overlook this information, it can't result in product damage by it's mishandling.



Indicates text that has important instruction character. If you overlook this information, it may result in product damage.

Thank you for purchasing BETSO product!

Please pay sufficient attention to the following user manual of your new product BETSO. Following these instructions, you will avoid the possible damages of your new device and at the same time, they will be presented to you all the available features that allow you to take advantage of the potential of the product.

For the latest information about our products BETSO please contact your local distributor or visit our website <http://www.betso.eu>.

1. Product description

The BETSO TCX-2 is ultra compact highly accurate time code transceiver. It is based on our very easy to use "plug and play" philosophy, which is guaranteed by wide OLED display and easily replaceable single AA battery.

Wireless time code transmission from unit set as TX provides distribution of time code with 0 frame drift (over infinite period of time) to all units set as RX. RX units jammend to TX perform as generators at same time as receivers, which means, that even if RX loses wireless signal from TX, it will keep generating correct time code. Our new digital RF link protocol furthermore offers great feature of wireless device state monitoring. So each unit connected to the network has perfect overview off all other connected units.

Small dimensions, long battery life, intuitive menu based operation of TCX-2 and above described new wireless capabilities make TCX-2 ideal for ENG/EFP or studio usage.

2. Top features

- works with all frame rates (23.976 fps - 30 fps) drop frame and non drop frame SMPTE TC formats includes its 0.5 and 2 multiples (12.5 fps, 15 fps, 50 fps, etc.)
- wireless digital RF link protocol for time code distribution and units state monitoring
- precise mechanic construction from anodized aluminium alloy
- BNC connector for timecode input/output
- optional displaying of time code / user bits
- 3 levels of display brightness
- intuitive control with quick, menu based setting of all advanced functions
- low consumption allowing operating time up to 80 hours (lithium cell, OLED PS mode, RF OFF)

- advanced monitoring of batteries level with signalization of discharged batteries
- power saving function which allows to dim or turn off OLED display when no user activity is detected
- Automatic ON & JAM function, which allows to turn on and JAM simultaneously without need to turn TCX-2 on first
- Variable powering using 1x AA batteries/accu
- USB connector for easy firmware upgrade

3. Control elements

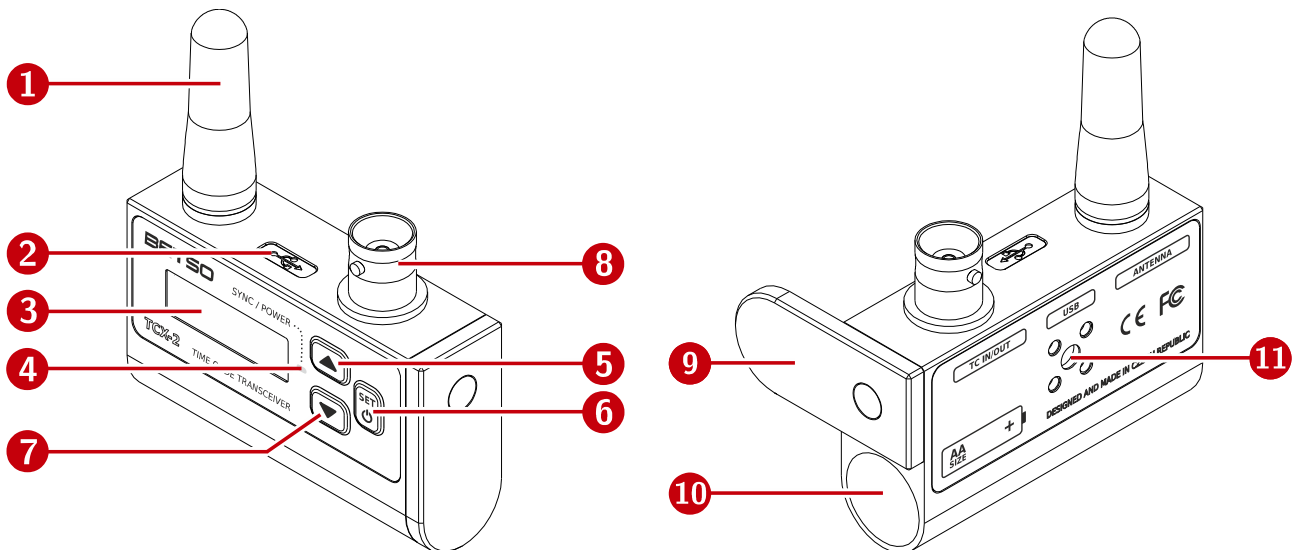

1. Antenna
2. MicroUSB connector
3. OLED display
4. Informative LED
5. Button „UP“
6. Button „SET“
7. Button „DOWN“
8. BNC connector for TC input/output
9. Battery door
10. Battery compartment
11. BETSO Hot Shoe holder mounting holes

4. Insertion of battery / accumulator

To power TCX-2 insert one AA alkaline/lithium cell or accumulator. After checking right polarity of inserted battery according to back side label, close the door.



TCX-2 is protected against destruction by inserting battery with wrong polarity.



Warning: Never leave battery inside of a product which will be unused for more than a week! Never leave discharged battery inside to avoid battery leakage!

5. Turning ON/OFF

Turning device ON long press of **SET** button

Turning device OFF long press of **SET** button until “Off” widget is highlighted



After turning ON the TCX-2, there will be displayed BETSO logo and after that, TCX-2 will start to operate according to previous setting in the menu.



If jamming is enabled, TCX-2 is set as TX and there is an external TC source connected to TCX-2, it starts to jam immediately.

6. Menu control

Enter the menu long press of **SET** button until “Menu” widget is highlighted

Exit the menu long press of **SET** button in main menu

Enter the submenu short press of **SET** button

Exit the submenu long press of **SET** button

Move up short press of **UP** button

Move down	short press of DOWN button
Enter the setting	short press of SET button
Change setting	short press of UP / DOWN button
Confirm the setting	short or long press of SET button



After exiting of the menu, all critical changes will be made upon question confirmation, other changes are set immediately.



Setting will be saved during regular turning off process, unpredicted battery removal will result in unsaved menu setting. Low battery power off will save setting correctly.

7. Setting of TCX-2

Menu control is described in previous chapter 6 Menu control.

7.1 Time code

In this section of menu there are located all settings related with time code.

7.1.1 Frame rate * - setting frame rate of generated Time Code

** This feature is available only with TCX-2+ FW upgrade.*

Menu / Time code / Frame rate

This function allows to set different frame rate of generated time code. When cross jamming is enabled, this frame rate will be used after jamming. TCX-2 can generate any type of time code including 0.5 and 2.0 multiples of standard frame rates.

Standard rate TC:	30, 30DF, 29.97, 29.97DF, 25, 24, 23.976
2x multiplied rate TC:	60, 60DF, 59.54, 59.54DF, 50, 48, 47.952
0.5x multiplied rate TC:	15, 15DF, 14.985, 14.985DF, 12.5, 12, 11.988

7.1.2 **Amplitude** - setting amplitude of generated Time Code

Menu / Time code / Amplitude

This function allows to set output amplitude of generated time code on BNC output.

TC amplitude: **+6dBu, +3dBu, 0dBu, -3dBu, -6dBu, -9dBu, -12dBu, -15dBu, -18dBu, -21dBu, -24dBu, -27dBu, -30dBu,**



This function is very useful when using TCX-2 with small DV camcorders or photo cameras without TC input when standard amplitude of Time Code could overload audio input of device.

7.1.3 **Default *** - setting of default Time Code start time/frame

** This feature is available only with TCX-2+ FW upgrade.*

Menu / Time code / Default

This function allows to set up default beginning time and frame of generated time code after turning TCX-2 on.

HH:MM:SS:FF HH: hours, MM: minutes, SS: seconds, FF: frame number



Invalid drop frame time code formats are permitted.

7.1.4 **Offset** - setting of Time Code offset for jamming or RF transmission

Menu / Time code / Offset

This function allows to set offset of generated time code related to jamming source or TX in RF RX mode.

-10.0 fr to +10.0 fr offset setting from -10 frames to +10 frames in step of 0.1 frames



This function is very helpful for compensation of TC offset when using some types of HD camcorders.

7.1.5 **User bits** - setting of User Bits of generated Time Code

Menu / Time code / User bits

TCX-2 allows to choose one of the following possible User bits sources, which will be inserted in the generated time code.

As jammed TC User bits of generated TC are the same as User bits of jamming source at the time of jamming

Manual UB User bits of generated TC are manually set in format:

U₈U₇:U₆U₅:U₄U₃: U₂U₁

Each User bit can be set in the range of 0 - 9, A - F

7.1.6 **Auto on** - setting of automatic power on when TC source is connected

Menu / Time code / Auto on

This function allows to turn on TCX-2 when TC source is connected to BNC connector. When Enable + JAM is set, jamming will start immediately after TCX-2 is turned on and TC source is still connected to BNC input.

Enable Auto on function is enabled

Enable + JAM * Auto on function is enabled and jamming starts after turning on

Disable Auto on function is disabled

** This feature is available only with TCX-2+ FW upgrade.*



We recommend to set this option to „Enable“ or „Enable + JAM“. Then you can easily turn on and JAM TCX-2 to external TC source and avoid necessity to use standard turning ON/OFF and jamming procedure.

7.1.7 Jamming * - setting of jamming to external TC source

** This feature is available only with TCX-2+ FW upgrade.*

Menu / Time code / Jamming

Once / Manual	TCX-2 can be jammed once without asking and then user has to confirm next jamming
Continuous (BNC = TC input)	TCX-2 will be jammed without asking every time new TC source is inserted
Disable	Automatic jamming is disabled. Useful for forced master mode. Jamming is still available upon request



When jamming continuous option is selected, TCX-2 is set as TX and external TC source is connected, every time measured TC offset exceeds 0.05 frames, TCX-2 jams to this new time code.

7.1.8 Cross jamming * - jamming TCX-2 with different TC frame rate

** This feature is available only with TCX-2+ FW upgrade.*

Menu / Time code / Cross jamming

This function enables TCX-2 to be jammed from external TC source preserving TC frame rate set in TC frame rate option (chapter 7.1.1).

Enable	Cross jamming is enabled
Disable	Cross jamming is disabled



Example. When TCX-2 is set to 25 fps and TC source has 30 fps, TCX-2 will be jammed to external TC time/frames, but will have the same frame rate as set in TC frame rate, in this case 25 fps.

7.1.9 Jamming calibration - calibration to TC source during jamming

Menu / Time code / Jamming calibration

This function enables or disables TCX-2 to perform calibration to time code precision of time code source during jamming.

OFF Jamming calibration is turned off

ON Jamming calibration is turned on



Ultimate advantage of jamming calibration feature is, that TCX-2 will be in much better synchronization to time code source, when this feature is enabled. E.g. standard precision of TCX-2 after GPS calibration is +/- 0.05 ppm. Considering that industry standard of other manufacturers is much worse around +/- 0.5 ppm and taking in account aging of up to +/- 1 ppm and other factors as temperature etc..., total error can be significantly more than +/- 1 ppm. This error will not arise, when jamming calibration is turned ON, with this feature TCX-2 can get in sync with time code source to precision of +/-0.1 ppm.



Warning: When using with Zaxcom recorders which have a jitter in timecode output, jamming calibration should be turned off!

7.2 Wireless

In this section of menu there are located all settings related with wireless behaviour of TCX-2.

7.2.1 Unit type - setting of wireless behaviour of TCX-2

Menu / Wireless / Unit type

This function allows to choose wireless behaviour of TCX-2. One of the following settings can be used:

- RF OFF *** TCX-2 doesn't use wireless transmission and works in cable mode
- TX** TCX-2 is configured to transmit time code on one of the selected channel. All RXs on the same channel will jam to TX
- RX** TCX-2 is configured to receive time code on one of the selected channel and jam to transmitting TX. To identify each RX in the wireless network, one ID number has to be selected in the range of **ID 1 ... ID 20**

** This feature is available only with TCX-2+ FW upgrade.*



When TCX-2 is used as single device on the set, we recommend to use RF OFF mode to save battery life.

7.2.2 Channel - setting of RF time code system channel

Menu / Wireless / Channel

TCX-2 incorporates our new digital RF link protocol which uses frequency hopping spread spectrum to extend wireless range and noise immunity to maximum possible values. The user can operate up to five independent RF time code systems using different channel for each time code system.

Set same channel on each device intended to connect to the same TX:

Channel **1 ... 5**

7.2.3 Location - setting of usage location for regulatory compliance

Menu / Wireless / Location

Depending of location on the World, where TCX-2 is being used, correct corresponding setting of Location has to be made in menu setting to ensure regulatory compliance. Change of this parameter is protected by password "**1993**".

Europe	Use when you operate TCX-2 in Europe
USA & Canada	Use when you operate TCX-2 in USA or Canada
Japan	Use when you operate TCX-2 in Japan



Change of this parameter is protected by password "**1993**".



Warning: Never use different location setting than location where product is currently used!

7.3 Special

In this section of menu there are located other special features not directly related with previous categories. E.g. power saving features etc...

7.3.1 Copy TX TC-IN to RX TC-OUT

Menu / Special / Copy TX TC-IN to RX TC-OUT

This feature works different on TX and RX and applies only when device is set to one of these wireless Unit types. Bellow is described corresponding behavior for TX and RX.

OFF feature is turned off

ON feature is turned on

TX when device is configured as TX and Copy TX TC-IN to RX TC-OUT feature is turned on, this setting overwrites jamming setting and behaves as jamming continuous regardless the jamming setting.

RX when device is configured as RX and Copy TX TC-IN to RX TC-OUT feature is turned on, the unit will generate time code all the time in synchronization with TX, but will output active time code only when there is active time code connected to TX.



This feature is useful e.g. in the case when recorders can be woken up by active time code. RX can be connected to such kind of recorder which can be woken up when needed by simply connecting active time code to TX without necessity to physically adjust RX or recorder itself.

7.3.2 **Battery type** – setting type of battery powering TCX-2

Menu / Special / Battery type

This function allows to choose right chemical type of cell powering TCX-2. Only then you can see the right status of the battery condition on OLED display.

Alkaline	TCX-2 is using alkaline cell
NiMH	TCX-2 is using NiMH cell
Lithium	TCX-2 is using lithium cell (1.5V only!)



We recommend to set right type of battery to get valid information about battery status and right turning OFF moment when the battery is dead.

7.3.3 **OLED brightness** – setting of OLED display brightness

Menu / Special / OLED brightness

High	OLED display has the highest brightness
Medium	OLED display has medium brightness
Low	OLED display has the lowest brightness



Notice that, the more brightness OLED display has, the bigger is current consumption and the battery will be sooner discharged.

7.3.4 **OLED power save mode** – setting of OLED power save function

Menu / Special / OLED power save mode

This function enables to set the behavior of the OLED display after 10 seconds without any user activity on buttons.

Display dim	Display is dimmed after 10s after last button pressing.
Display off	Display is turned off after 10s after last button pressing.
None	No action after 10s after last button pressing - power save mode disabled.



This function prolongs battery life and saves OLED display from burn.

7.3.5 Display orientation – setting of OLED display orientation

Menu / Special / Display orientation

Normal	OLED display is standardly oriented
Rotated	OLED display is rotated upside down



When OLED display is rotated, it doesn't mean, that **UP** and **DOWN** buttons functions are swapped. They remains the same as in normal mode.

7.4 System

In this section of menu there are located system informations without setting possibility.

7.4.1 Serial number - serial number of TCX-2

Menu / System / Serial number

Serial number provides unique identification for your TCX-2 for warranty and technical support.

7.4.2 Upgrade to TCX-2+ - allows TCX-2 FW upgrade

Menu / System / Upgrade to TCX-2+

By unlocking TCX-2+ features, you will get extended functionality of your TCX-2 ultra compact highly accurate Time Code transceiver. Functions of TCX-2+ are highlighted in this manual with * and blue color.

7.4.3 HW version - version of hardware of TCX-2

Menu / System / HW version

Version of TCX-2 motherboard hardware.

7.4.4 SW version - version of software of TCX-2

Menu / System / SW version

Version of TCX-2 firmware.



Actual firmware can be found at <http://www.betso.eu/support>.

7.4.5 GPS calibration – calibration of internal TCXO using GPS module

Menu / System / GPS calibration

This function allows to calibrate internal TCXO using GPS signal. It means that one second generated by TCX-2 will last the exactly same time as accurate GPS atomic clock based second.



Warning: Don't run GPS calibration as it will stop current TCX-2 time code functionality and will require restart before next operation. TCX-2 can be calibrated only by manufacturer or authorized distributor!

7.4.6 **Contains FCC ID: 2AJWB-RFM1** - inbuilt transmitter module

Menu / System / Contains FCC ID: 2AJWB-RFM1

To display information about inbuilt transmitter module, go to Menu / System where FCC ID of inbuilt transmitter is displayed.

TCX-2 Contains FCC ID: 2AJWB-RFM1

7.4.7 **Contains IC: 21968-RFM1** - inbuilt transmitter module

Menu / System / Contains IC: 21968-RFM1

To display information about inbuilt transmitter module, go to Menu / System where IC ID of inbuilt transmitter is displayed.

TCX-2 Contains IC: 21968-RFM1

8. Control of TCX-2

Following three types of main screen information are available for TCX-2

TC	TCX-2 shows actual time code generator state
WIRELESS STATES	TCX-2 shows information about all devices in the net
USER BITS	TCX-2 shows actual generated user bits

8.1 Unit type of TCX-2 is set to RF OFF *

** This feature is available only with TCX-2+ FW upgrade.*

short press **UP**

Toggles between these main screen pages:

TC -> **USER BITS** -> **TC**

short press **DOWN**

Return to main screen **TC** and shows system ask "Jam

	<i>to ext. TC?</i> if jamming to external time code required, confirm the ask by short press of SET button
long press of SET	until "Menu" widget is highlighted to enter the menu
long press of SET	until "Off" widget is highlighted to turn TCX-2 off



In this mode, BNC connector is set as time code output after successful jamming. When jamming or in turned off state, BNC connector is set as an input.

8.2 Unit type of TCX-2 is set to TX

short press UP	Toggles between these main screen pages: TC -> WIRELESS STATES -> USER BITS -> TC
short press DOWN	Return to main screen TC and shows system ask " <i>Jam to ext. TC?</i> " if jamming to external time code required, confirm the ask by short press of SET button
long press of SET	until "Menu" widget is highlighted to enter the menu
long press of SET	until "Off" widget is highlighted to turn TCX-2 off



In this mode, BNC connector is set as time code input.



In this mode, BNC connector is set as time code output after jamming and removing of cable with active timecode from BNC connector. *

** This feature is available only with TCX-2+ FW upgrade.*

8.3 Unit type of TCX-2 is set to RX

short press UP	Toggles between these main screen pages: TC -> WIRELESS STATES -> USER BITS -> TC
short press DOWN	Return to main screen TC
long press of SET	until "Menu" widget is highlighted to enter the menu
long press of SET	until "Off" widget is highlighted to turn TCX-2 off



In this mode, BNC connector is set as time code output.

9. Informative LED function

Master mode

Not jammed TCX-2 to external TC

LEDs flash with frequency equal to frame rate of generated Time Code

Slave mode

Jammed TCX-2 to external TC

LEDs flash every 00 frame of generated Time Code => once per second



Informative LED is very useful for checking if TCX-2 was jammed or not. For example if device was turned off and then turned on, user can see that there is a necessity to do the jamming of TCX-2.

10. Recommended accessories

Optional accessories include various cables for the connection of the TC signal and velcro protective case.

For the latest information about our products BETSO please contact your local distributor or visit our websites <http://www.betso.eu>

11. Troubleshooting

It is not possible to turn on TCX-2

Most probably battery inside of TCX-2 is dead. Please insert new battery and try it again. If problem still remains, please contact your BETSO distributor.



Warning: Never connect the outputs of TCX-2 to microphone inputs with phantom power turned on. It would cause serious damage of TCX-2.

Safety instruction



Never open an electrical device! All reparations must be performed by an authorized service center. In the case of opening of the device away from the authorized service center, you will automatically loose the warranty of the device.



Do not use the electrical device in the places with high humidity, especially take care to protect the device against direct contact with water.



To clean the device, use a dampened piece of cloth. Never use any chemical solvents!

12. Technical specification

Dimensions (w x h x d)	59 x 39 x 16 mm (2.35 x 1.37 x 0.62")
Display	Wide graphic OLED display with adjustable brightness
Weight	approx. 45 g (without battery)
Mechanical construction	anodized aluminum alloy
SMPTE TC signal	23,976 fps - 30 fps including DF and NDF (also 0.5 and 2 multiples: 11.98 fps - 60 fps supported)
TCXO Crystal	GPS calibrated temperature compensated oscillator (+/- 0.1 ppm)
Accuracy error	Less than 0.3 frames/24 hours (w/o RF transmission) 0.0 Fr with RF transmission
Input sensitivity	0,2 – 10 V (p-p)
Frequency range	902 - 928 MHz (USA/Canada) 863 - 870 MHz (Europe) 920.6 - 923.4 MHz (Japan)
Number of channels	5 different hopping schemes
RF output power	10mW (10dBm)
Operating range	up to 500m *
Powering	1x AA battery (alkaline, lithium or NiMH, NiCd)
Current consumption	approx. 40 – 150 mA **
Battery life	Up to 80 hours ***

* within the line of sight

** depends on the operating mode

*** with the power save function of OLED, RF off and Lithium cell

13. BNC connector wiring

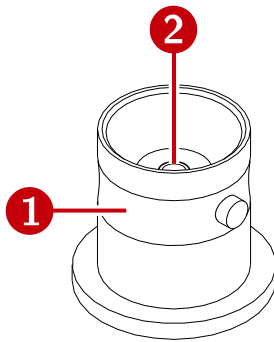

1. GND
2. TC input/output

14. FCC regulatory information (USA) FCC Statements

This device complies with part 15 of the FCC Rules. Operation is subject to the following two conditions:

- (1) This device may not cause harmful interference, and
- (2) this device must accept any interference received, including interference that may cause undesired operation.



Changes or modifications not expressly approved by the party responsible for compliance could void the user's authority to operate the equipment.



Note: This equipment has been tested and found to comply with the limits for a Class B digital device, pursuant to part 15 of the FCC Rules. These limits are designed to provide reasonable protection against harmful interference in a residential installation. This equipment generates, uses and can radiate radio frequency energy and, if not installed and used in accordance with the instructions, may cause harmful interference to radio communications. However, there is no guarantee that interference will not occur in a particular installation. If this equipment does cause harmful interference to radio or television reception, which can be determined by turning the equipment off and on, the user is encouraged to try to correct the interference by one or more of the following measures:

- Reorient or relocate the receiving antenna.
- Increase the separation between the equipment and receiver.
- Connect the equipment into an outlet on a circuit different from that to which the receiver is connected.
- Consult the dealer or an experienced radio/TV technician for help.

15. Industry Canada (IC) regulatory information

This device complies with Industry Canada's licence-exempt RSSs. Operation is subject to the following two conditions:

- (1) This device may not cause interference; and
- (2) This device must accept any interference, including interference that may cause undesired operation of the device.

Under Industry Canada regulations, this radio transmitter may only operate using an antenna of a type and maximum (or lesser) gain approved for the transmitter by Industry Canada. To reduce potential radio interference to other users, the antenna type and its gain should be so chosen that the equivalent isotropically radiated power (e.i.r.p.) is not more than that necessary for successful communication.

This radio transmitter IC ID: 21968-RFM1 has been approved by Industry Canada to operate with the antenna types listed below with the maximum permissible gain indicated. Antenna types not included in this list, having a gain greater than the maximum gain indicated for that type, are strictly prohibited for use with this device.

Antenna	Manufacturer	Impedance [Ω]	Gain [dBi]
ANT-868-PW-LP	Linx Technologies	50	2.1dBi

16. Avis de conformité à la réglementation d'Industrie Canada

Le présent appareil est conforme aux CNR d'Industrie Canada applicables aux appareils radio exempts de licence. L'exploitation est autorisée aux deux conditions suivantes:

- 1) l'appareil ne doit pas produire de brouillage;
- 2) l'appareil doit accepter tout brouillage radioélectrique subi, même si le brouillage est susceptible d'en compromettre le fonctionnement.

Conformément aux réglementations d'Industry Canada, les émetteurs radio de cet appareil ne peuvent fonctionner qu'à l'aide d'une antenne dont le type et le gain maximal (ou minimal) pour ces émetteurs - transmetteurs sont approuvés par Industry Canada. Pour réduire le risque d'interférence éventuelle pour les autres utilisateurs, le type et le gain de l'antenne doivent être choisis de manière à ce que la puissance isotrope rayonnée équivalente (p.i.r.e.) minimale nécessaire à une bonne communication soit fournie.

Le présent émetteur radio IC ID: 21968-RFM1 a été approuvé par Industrie Canada pour fonctionner avec les types d'antenne énumérés ci-dessous et ayant un gain admissible maximal. Les types d'antenne non inclus dans cette liste, et dont le gain est supérieur au gain maximal indiqué, sont strictement interdits pour l'exploitation de l'émetteur.

Antenna	Fabricant	Impédance [Ω]	Gain [dBi]
ANT-868-PW-LP	Linx Technologies	50	2.1dBi

To comply with FCC and Industry Canada RF radiation exposure limits for general population, the antenna(s) used for this transmitter must be installed such that a minimum separation distance of 20cm is maintained between the radiator (antenna) and all persons at all times and must not be co-located or operating in conjunction with any other antenna or transmitter.

17. EC Declaration of conformity



BETSO ELECTRONICS s.r.o.

Elisky Premyslovny 1335, 156 00 Prague 5 – Zbraslav, Czech Republic

Reg. number: 28955706

declare that this device

BETSO TCX-2

specification: Ultra compact highly accurate Time Code transceiver

frequency range: 863 - 870 MHz (Europe)

radiated power: 10 mW (10 dBm) max.

conform to the essential requirements of the R&TTE Directive 1999/5/EC. To demonstrate compliance with these requirements, the following standards were consulted:

EN 300 220 (Radio spectrum Matters ERM)

EN 301 489 (Electromagnetic Compatibility)

EN 60065/2002 (Safety of Electrical Equipment)

Conformity assessed via Annex III. using a Technical Construction and Results of measurements.

December 2016

A handwritten signature in blue ink, appearing to read 'J. Zastera', is written over a light blue rectangular background.

Ing. Jan Zastera

general manager

E-mail: zastera@betso.eu